

SYSTEM WIRING DIAGRAMS

Cooling Fan Circuit

1988 Volvo 740

For x

Copyright © 1998 Mitchell Repair Information Company, LLC

Friday, July 23, 2004 08:44PM

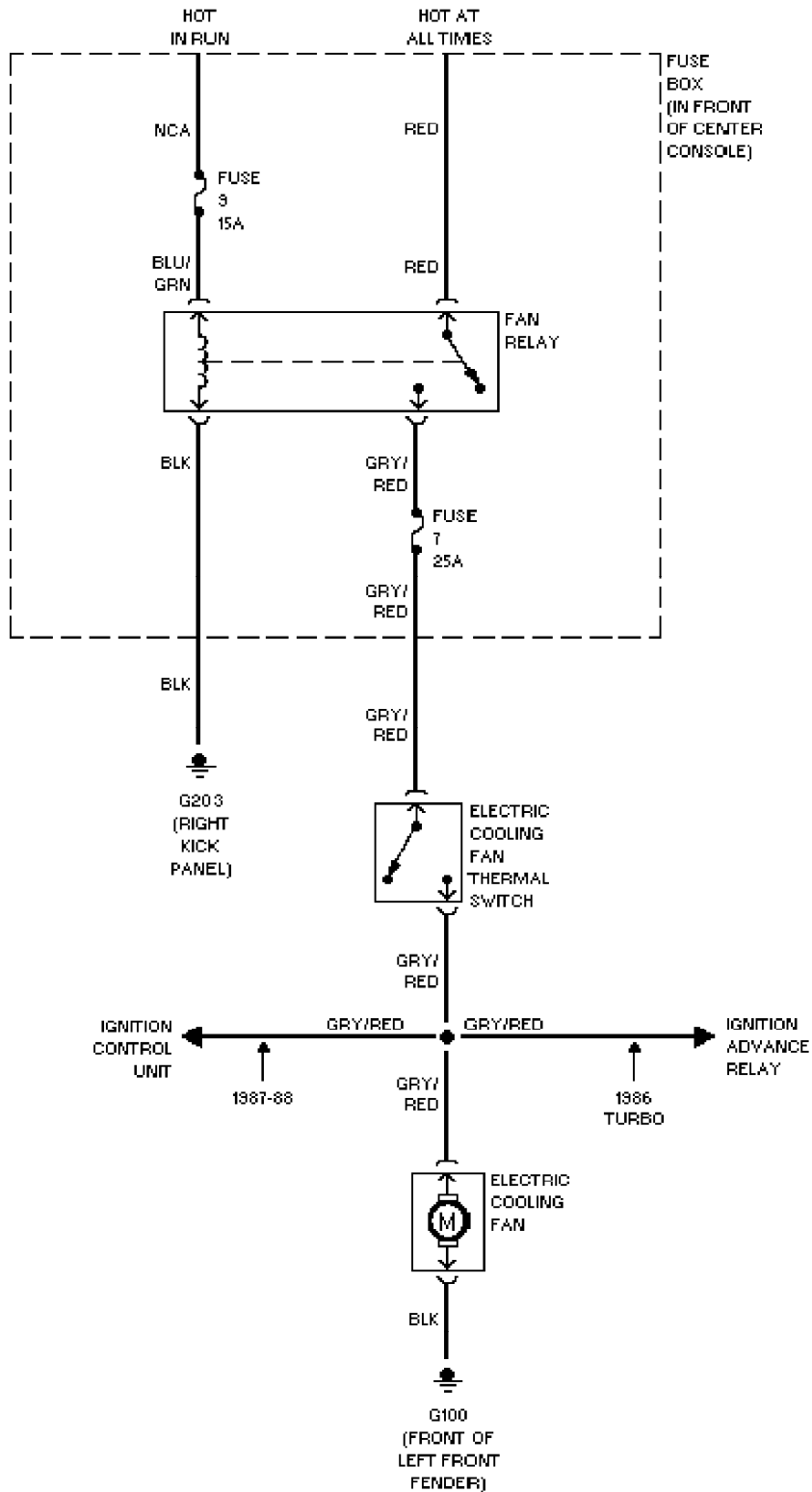

SYSTEM WIRING DIAGRAMS

Starting Circuit

1988 Volvo 740

For x

Copyright © 1998 Mitchell Repair Information Company, LLC

Friday, July 23, 2004 08:45PM

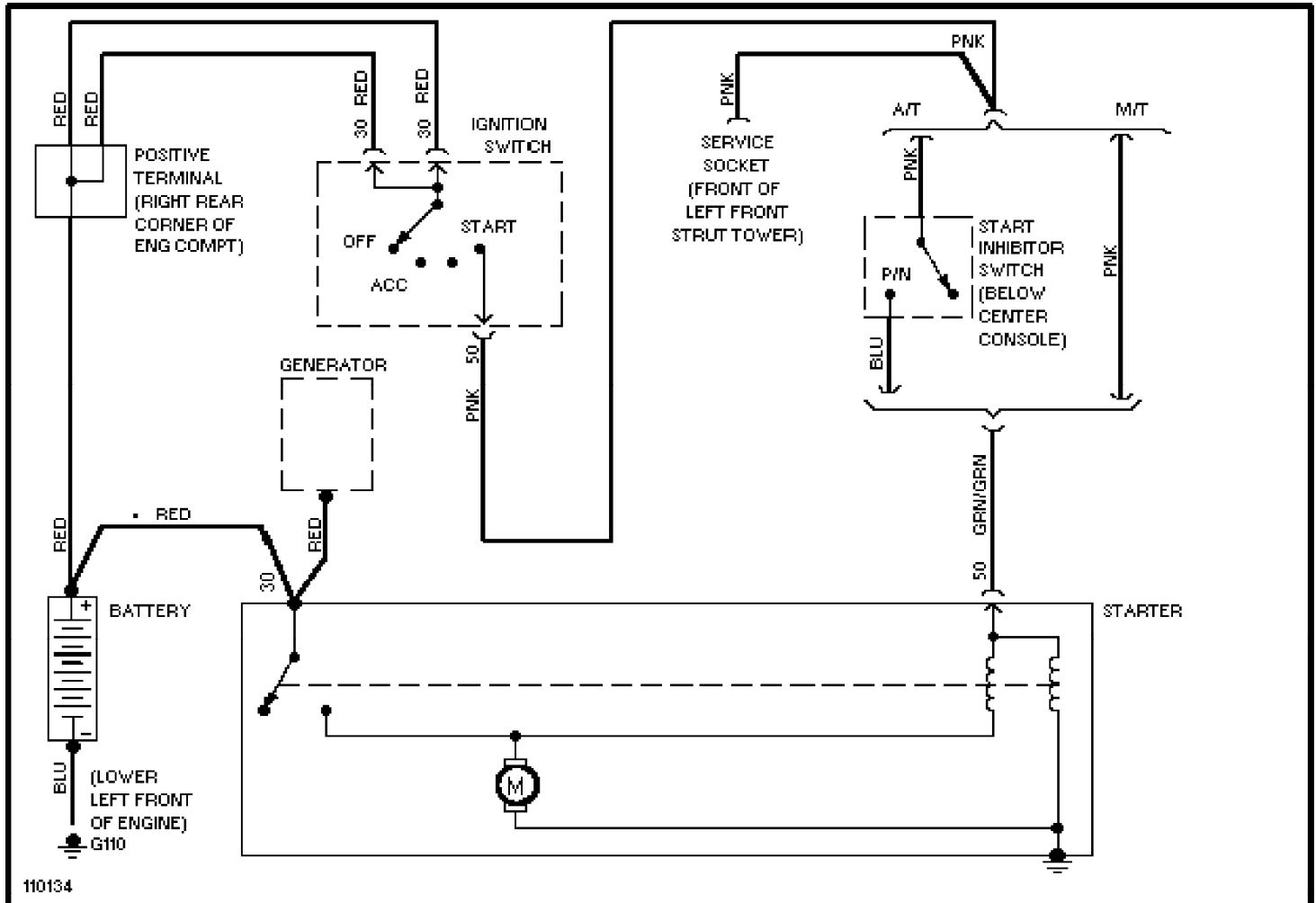

SYSTEM WIRING DIAGRAMS

Front Wiper/Washer Circuit

1988 Volvo 740

For x

Copyright © 1998 Mitchell Repair Information Company, LLC

Friday, July 23, 2004 08:45PM

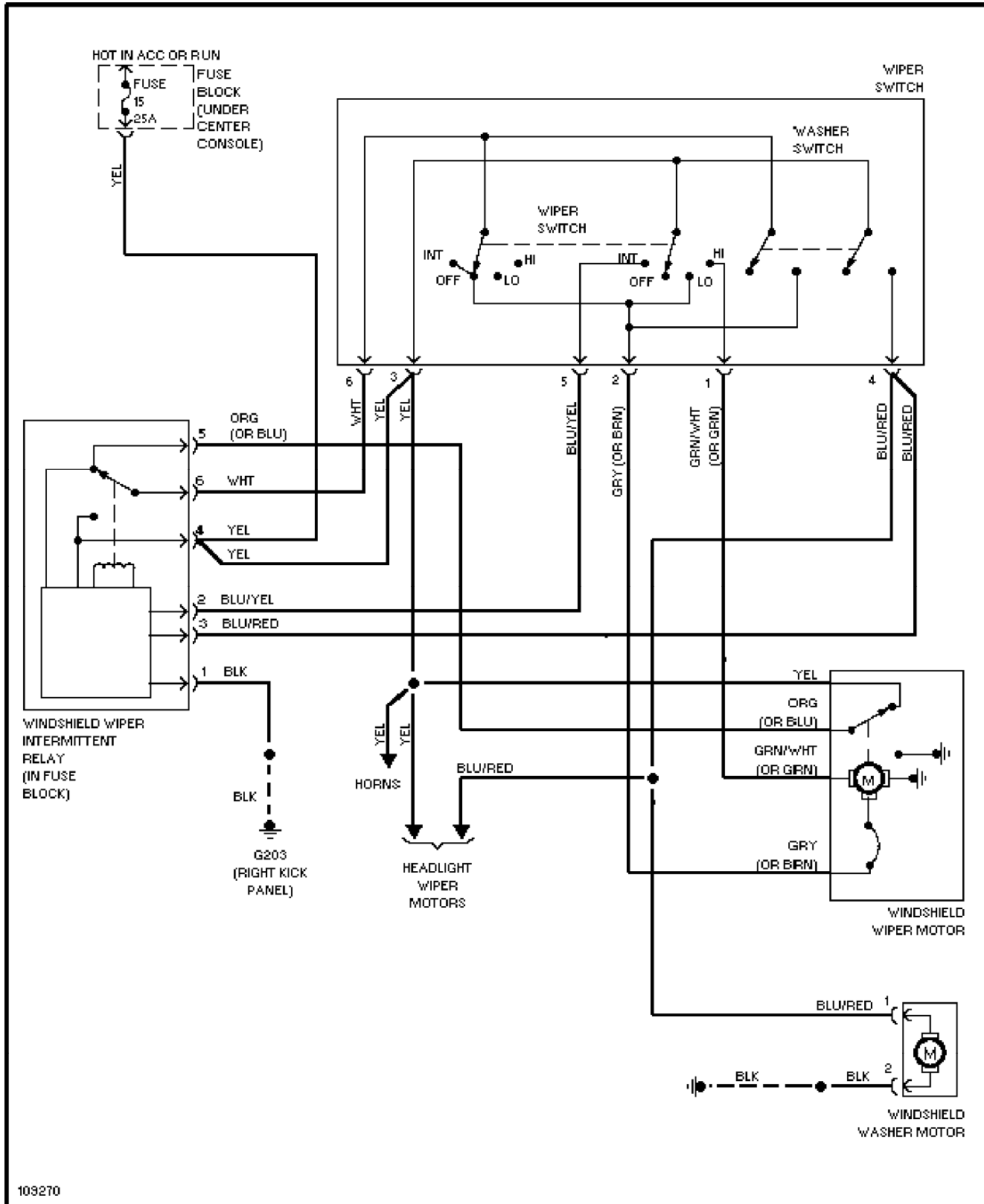

SYSTEM WIRING DIAGRAMS

Rear Wiper/Washer Circuit

1988 Volvo 740

For x

Copyright © 1998 Mitchell Repair Information Company, LLC

Friday, July 23, 2004 08:45PM

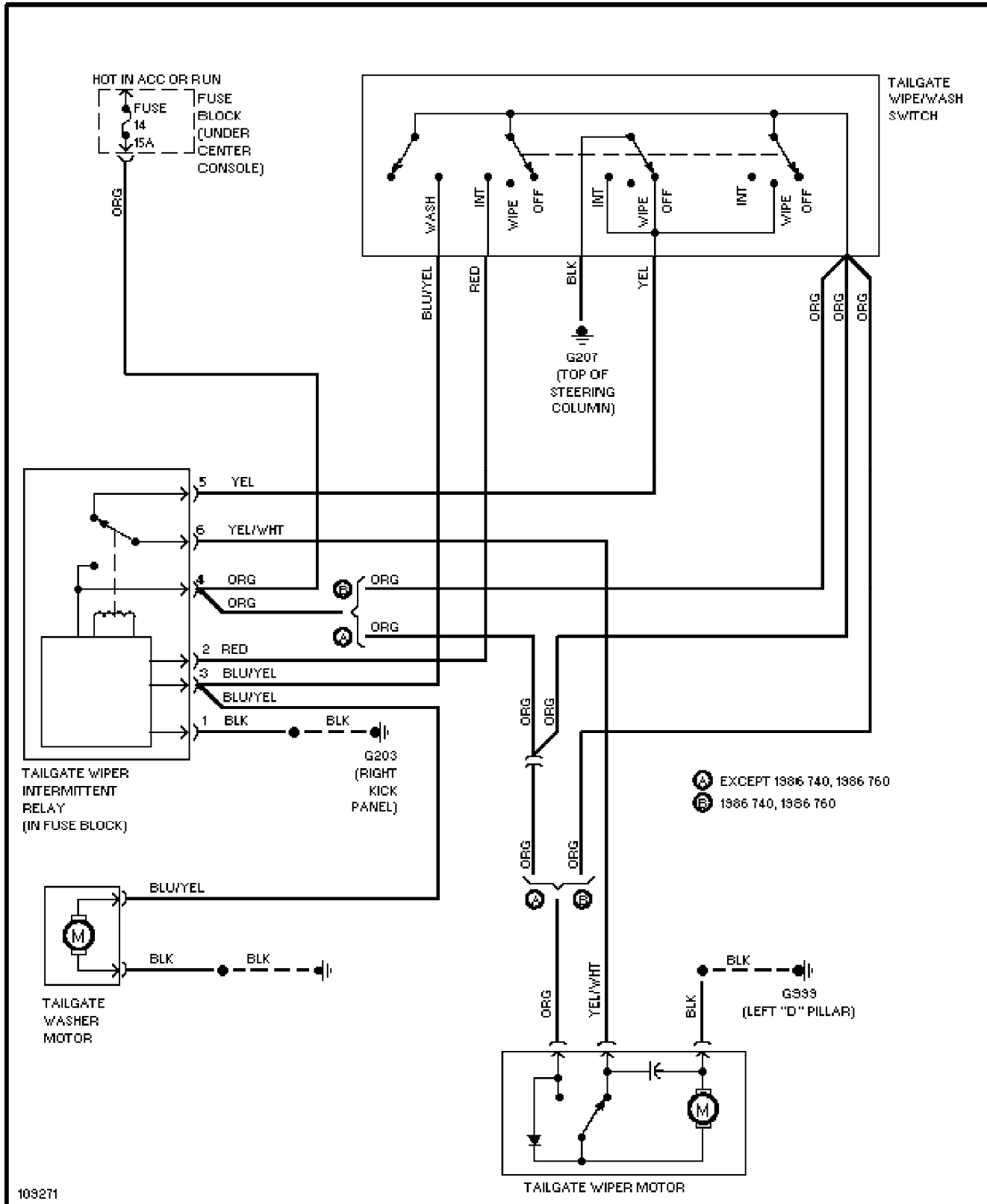

SYSTEM WIRING DIAGRAMS

Defogger Circuit

1988 Volvo 740

For x

Copyright © 1998 Mitchell Repair Information Company, LLC

Friday, July 23, 2004 08:45PM

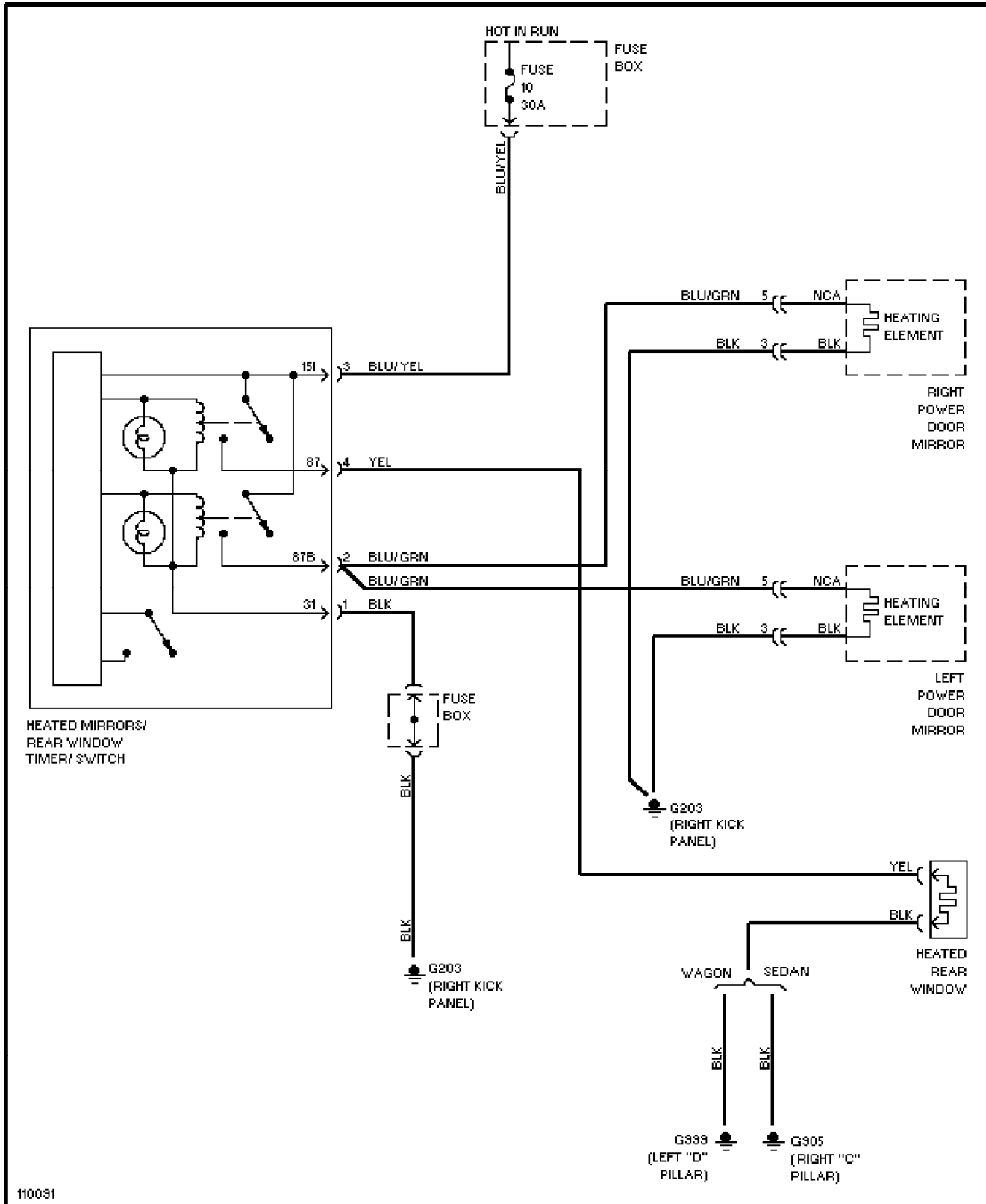

SYSTEM WIRING DIAGRAMS

Horn Circuit

1988 Volvo 740

For x

Copyright © 1998 Mitchell Repair Information Company, LLC

Friday, July 23, 2004 08:45PM

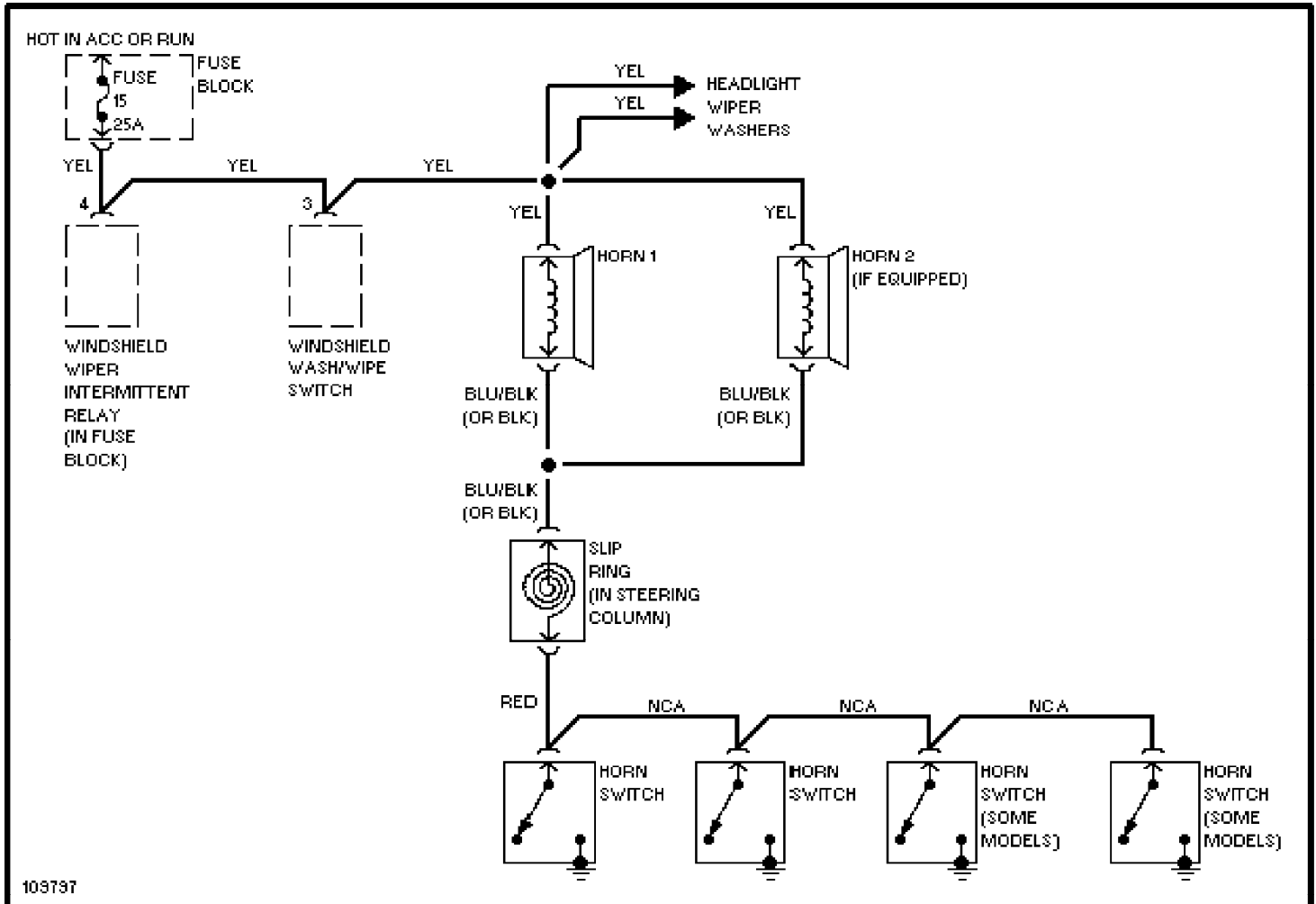

SYSTEM WIRING DIAGRAMS

Power Antenna Circuit

1988 Volvo 740

For x

Copyright © 1998 Mitchell Repair Information Company, LLC

Friday, July 23, 2004 08:45PM

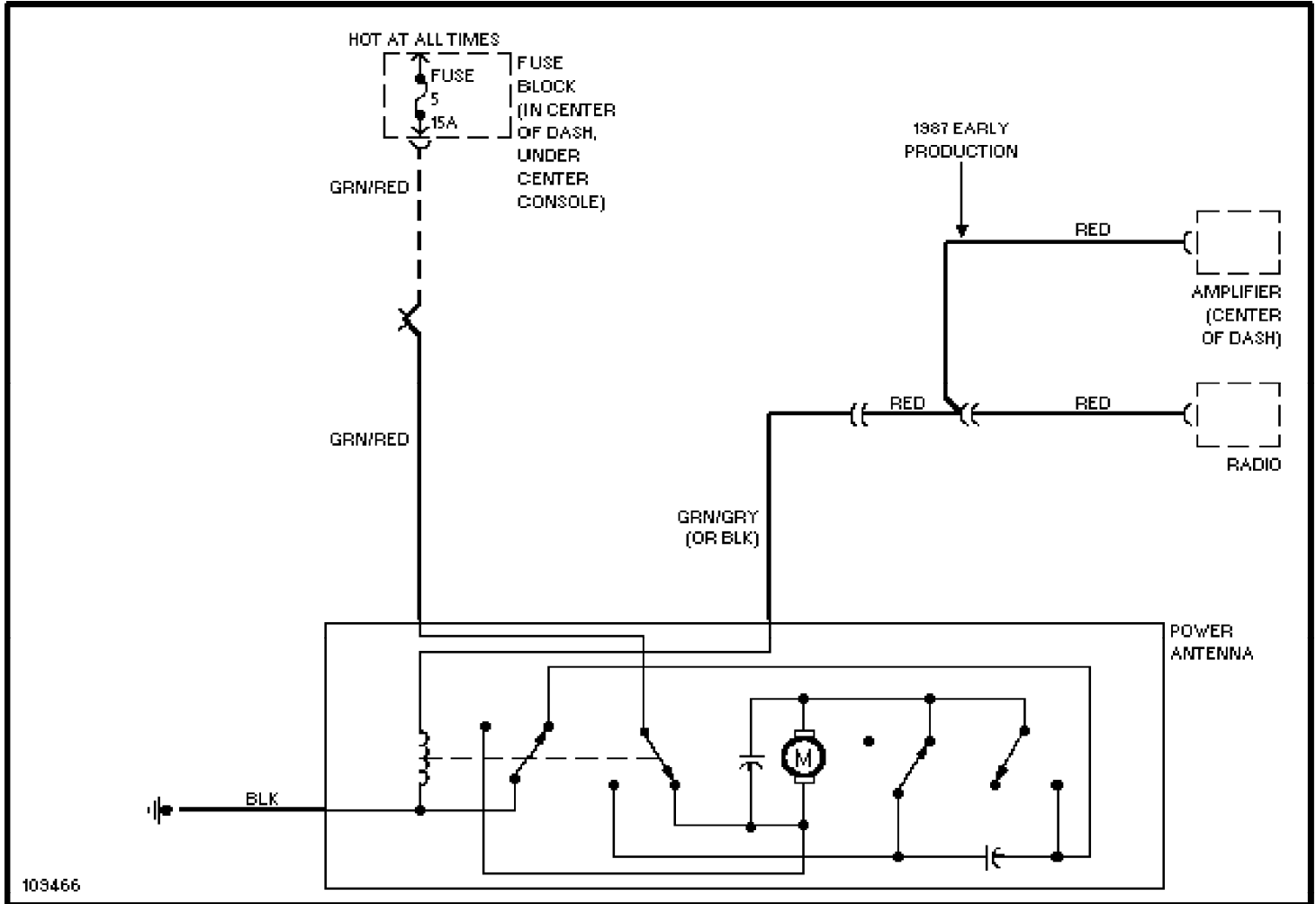

SYSTEM WIRING DIAGRAMS

Power Mirror Circuit

1988 Volvo 740

For x

Copyright © 1998 Mitchell Repair Information Company, LLC

Friday, July 23, 2004 08:45PM

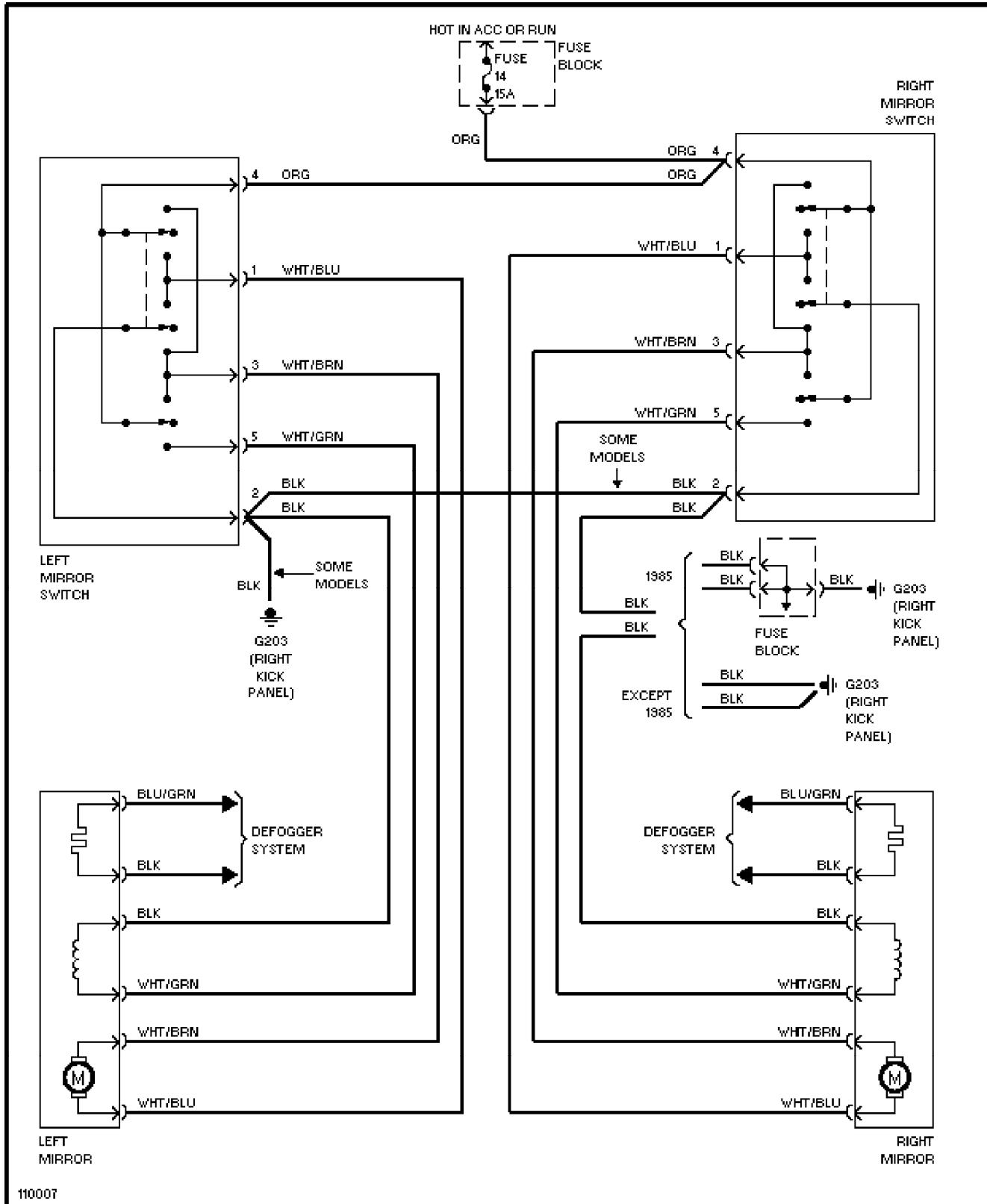

SYSTEM WIRING DIAGRAMS

Heated Seats Circuit, Dual Output

1988 Volvo 740

For x
 Copyright © 1998 Mitchell Repair Information Company, LLC
 Friday, July 23, 2004 08:45PM

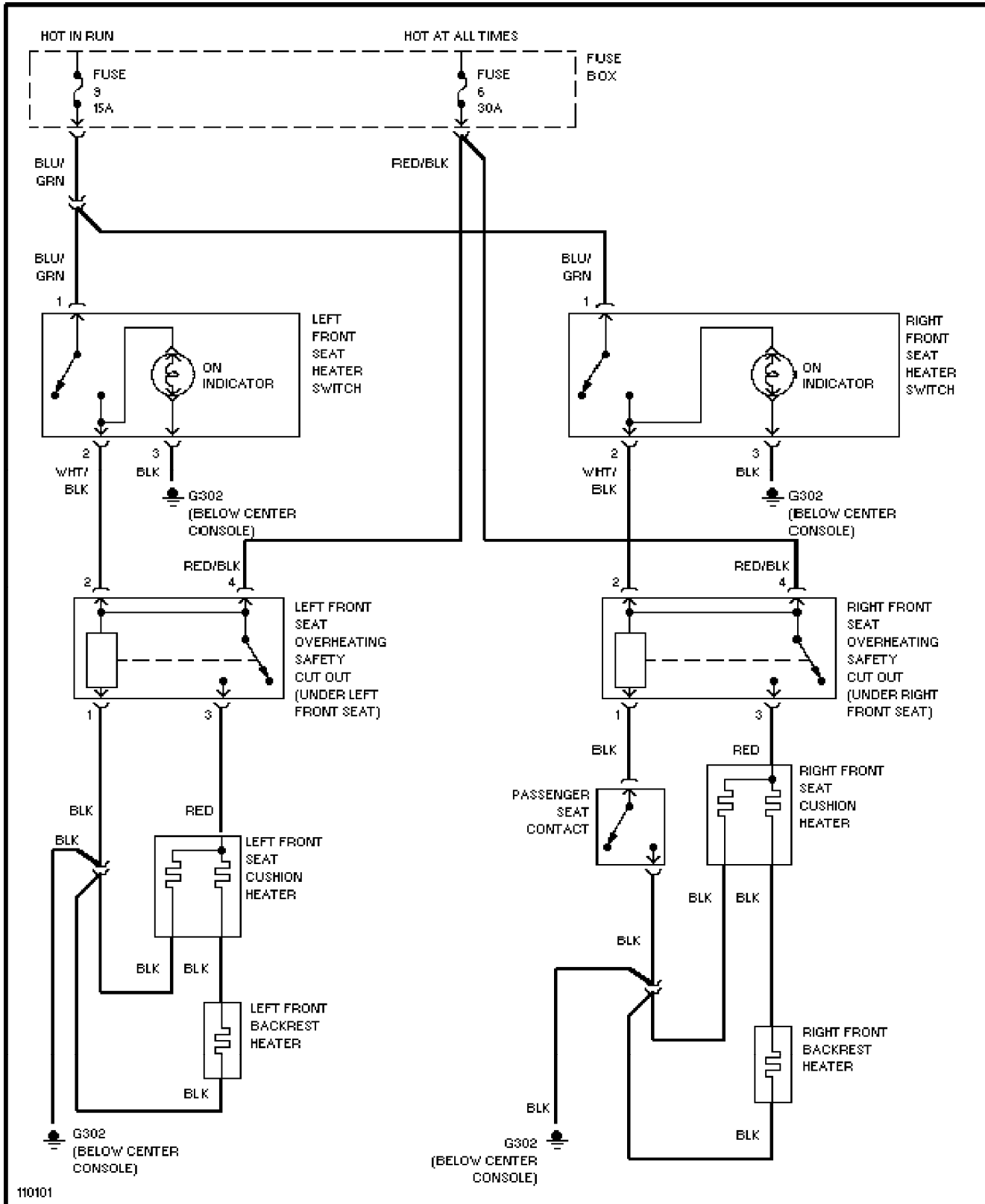

SYSTEM WIRING DIAGRAMS

Heated Seats Circuit, Single Output

1988 Volvo 740

For x

Copyright © 1998 Mitchell Repair Information Company, LLC
Friday, July 23, 2004 08:45PM

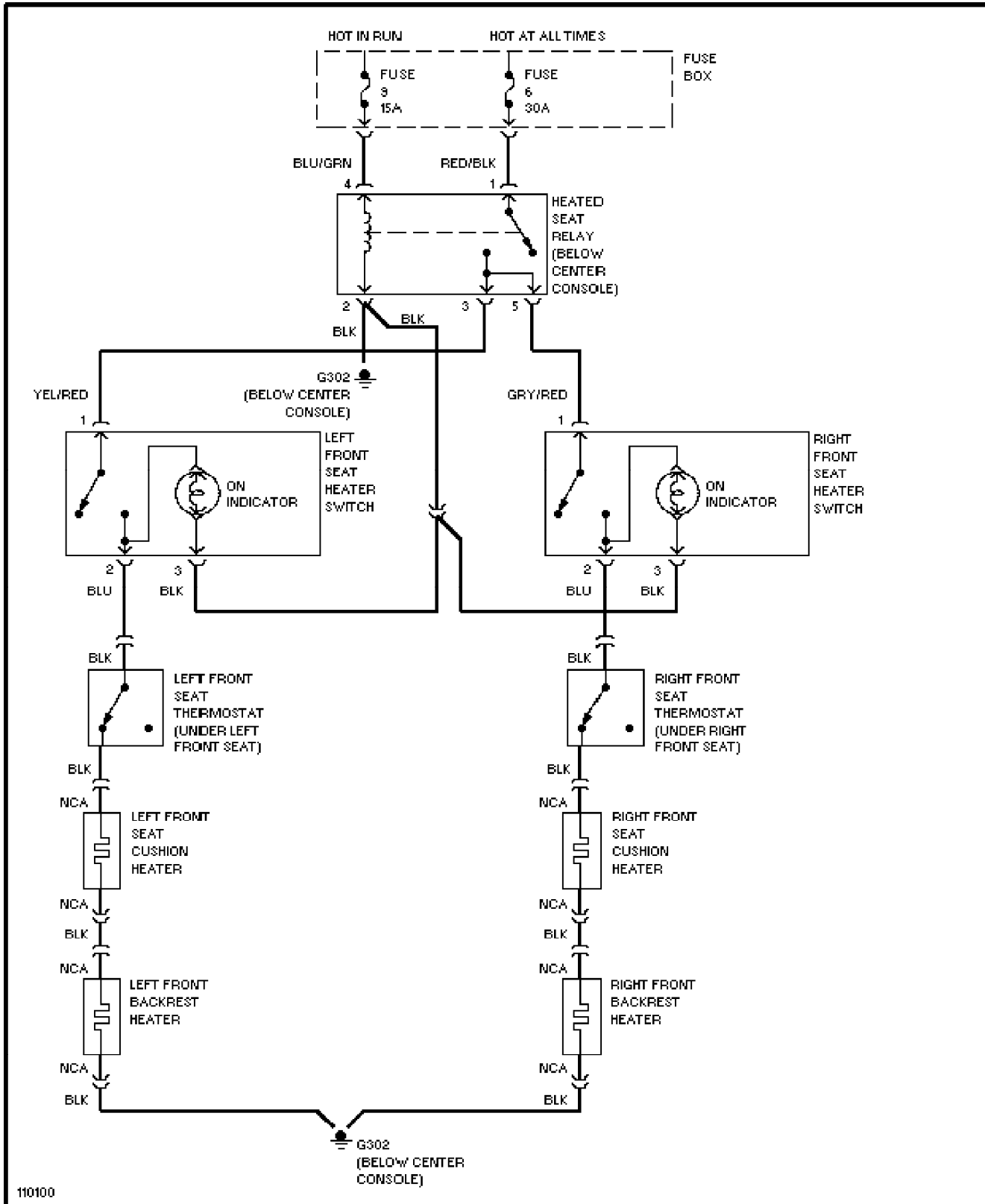

SYSTEM WIRING DIAGRAMS

Power Window Circuit

1988 Volvo 740

For x

Copyright © 1998 Mitchell Repair Information Company, LLC

Friday, July 23, 2004 08:45PM

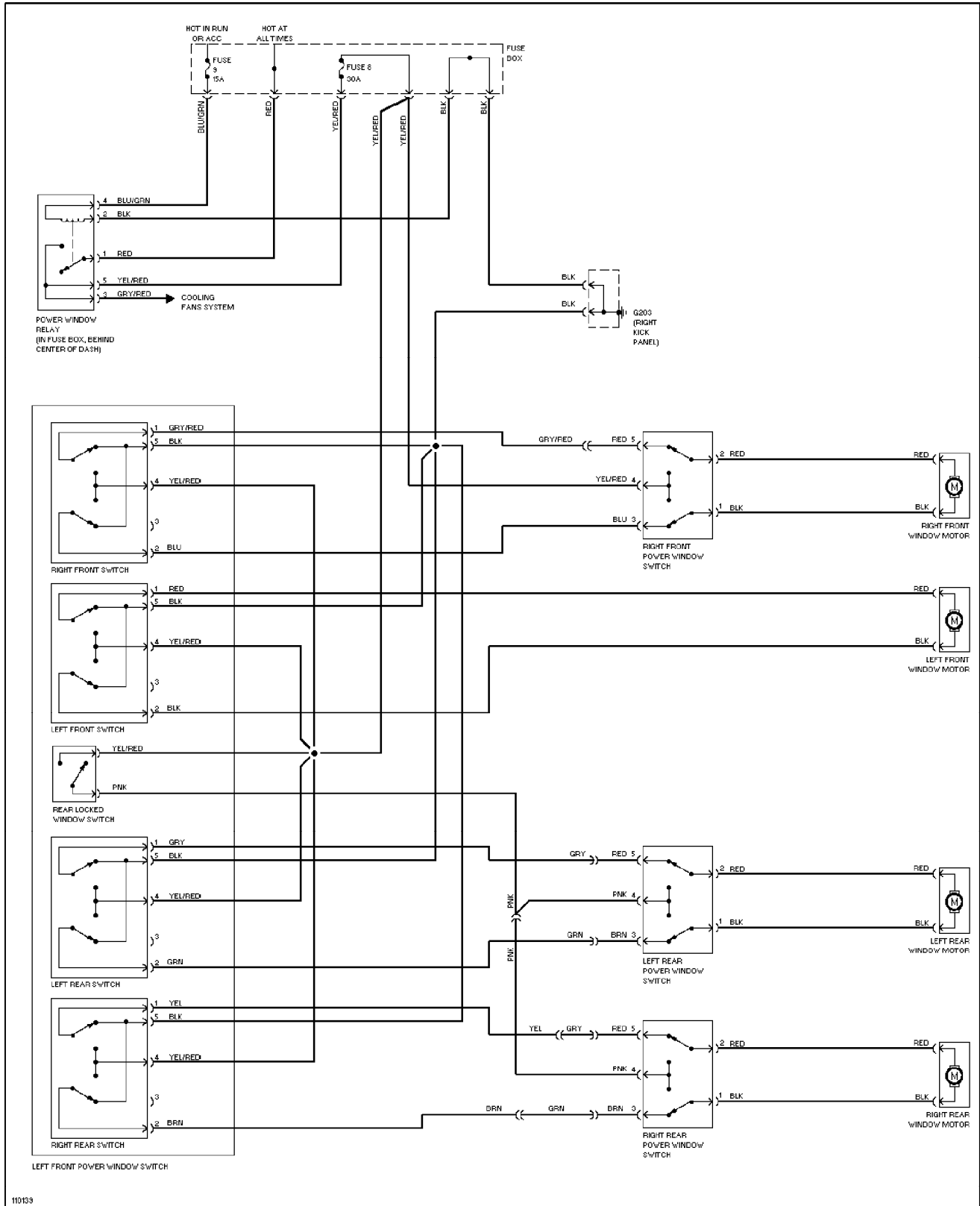

SYSTEM WIRING DIAGRAMS

Radio Circuits

1988 Volvo 740

For x

Copyright © 1998 Mitchell Repair Information Company, LLC

Friday, July 23, 2004 08:45PM

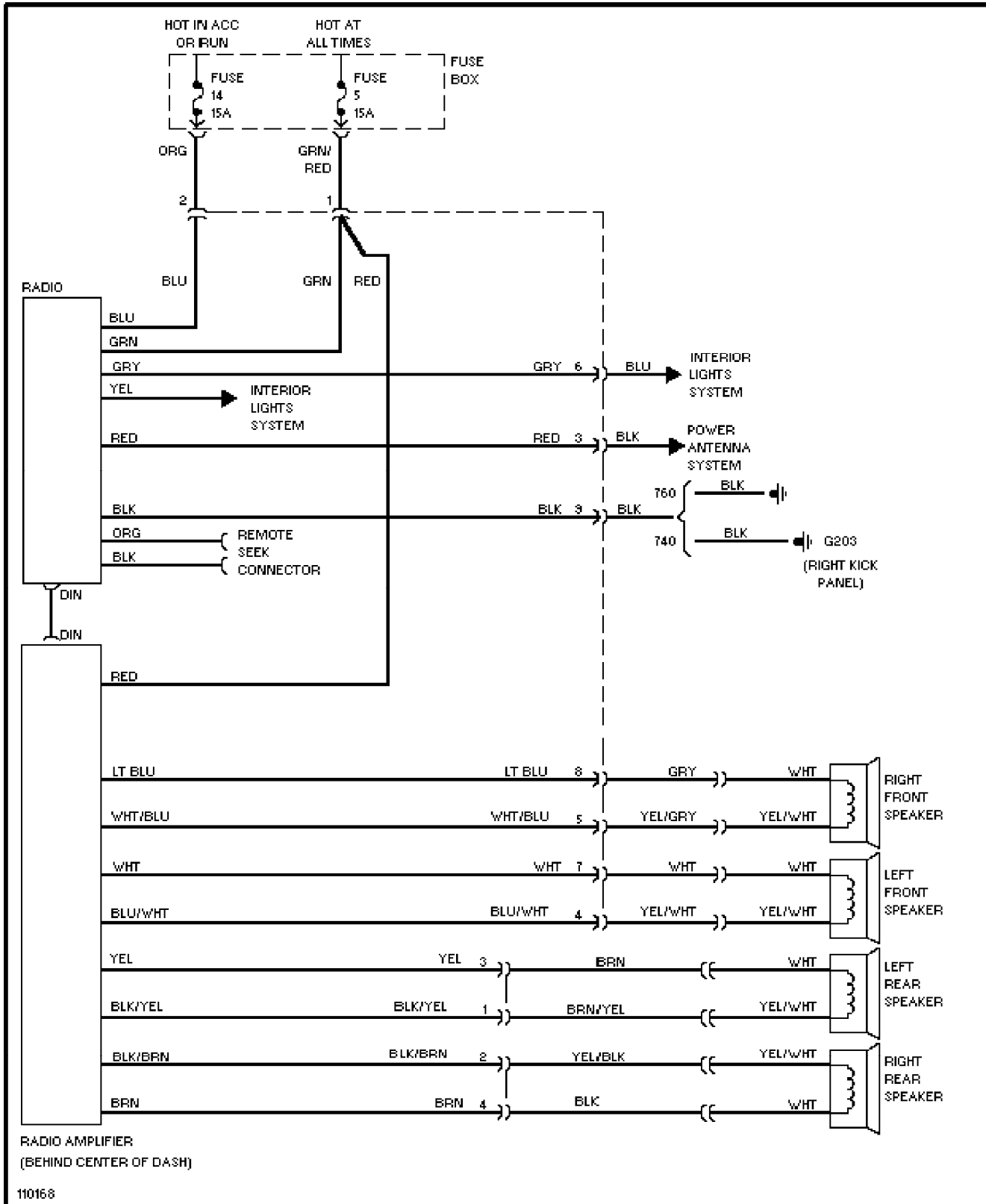

SYSTEM WIRING DIAGRAMS

Charging Circuit

1988 Volvo 740

For x

Copyright © 1998 Mitchell Repair Information Company, LLC

Friday, July 23, 2004 08:45PM

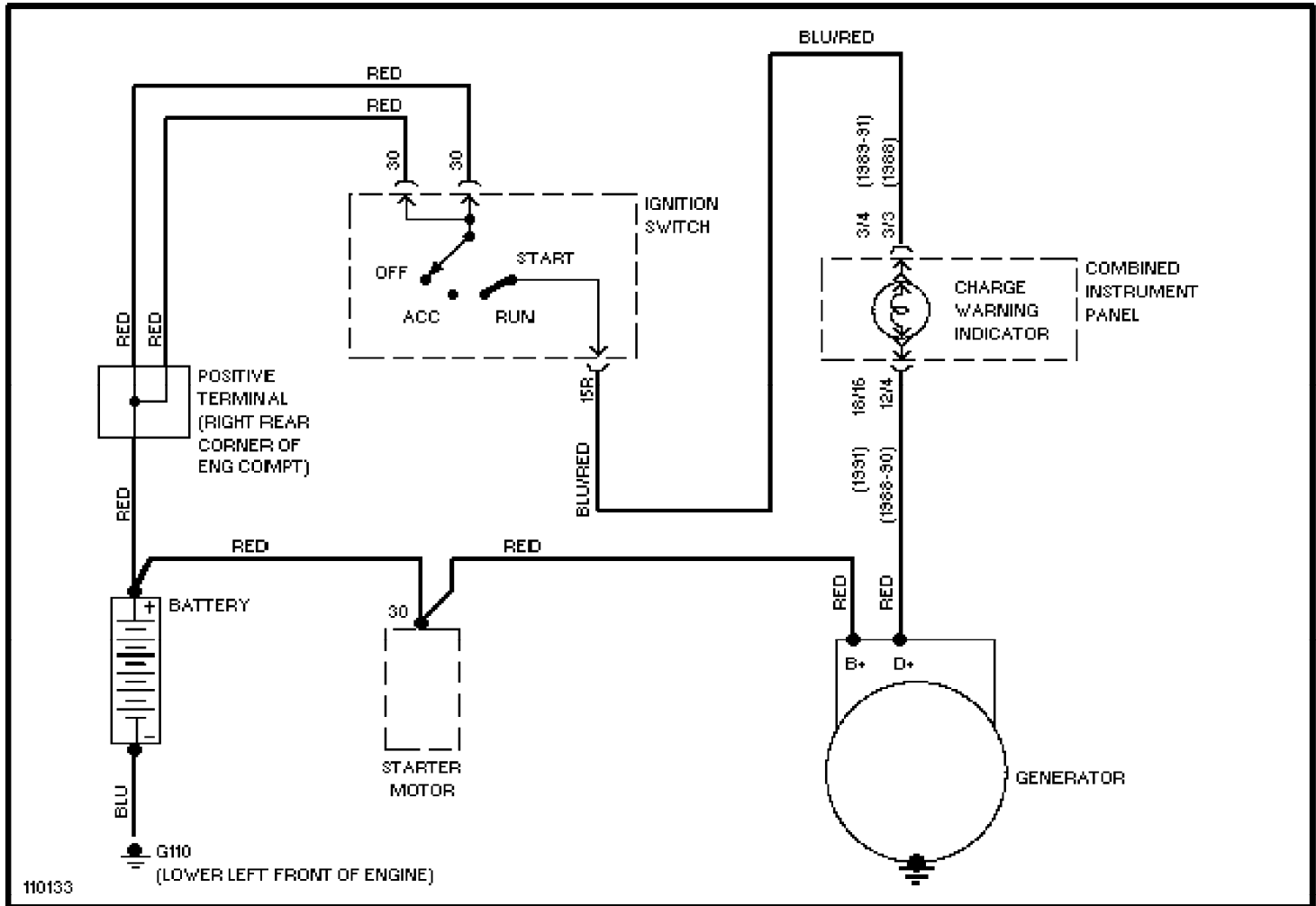

WIRING DIAGRAMS

Fig. 7: Instrument Panel

1988 Volvo 740

For x

Copyright © 1998 Mitchell Repair Information Company, LLC

Friday, July 23, 2004 08:46PM

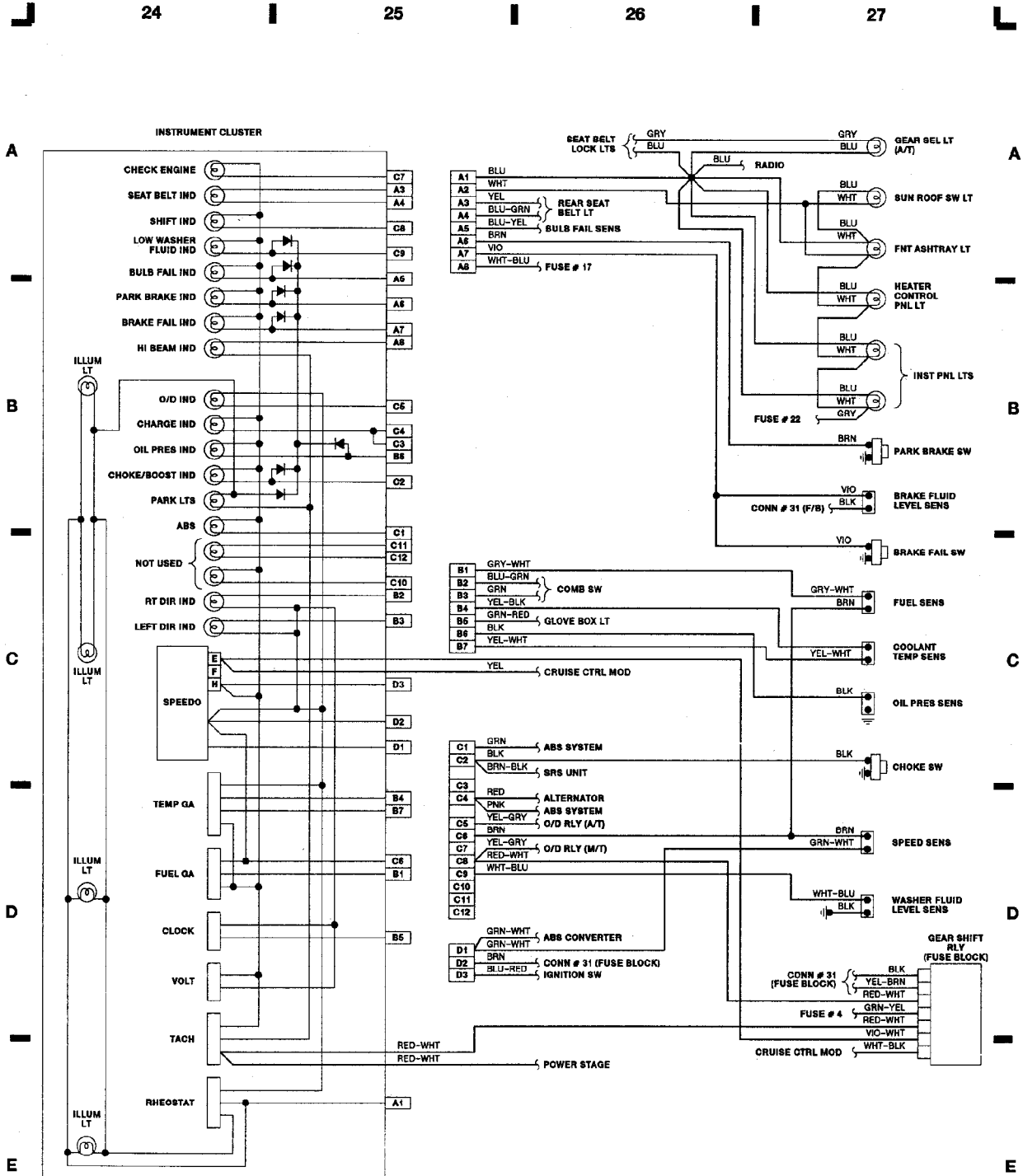

WIRING DIAGRAMS

Fig. 8: Accessories (Cont.)

1988 Volvo 740

For x

Copyright © 1998 Mitchell Repair Information Company, LLC
Friday, July 23, 2004 08:46PM

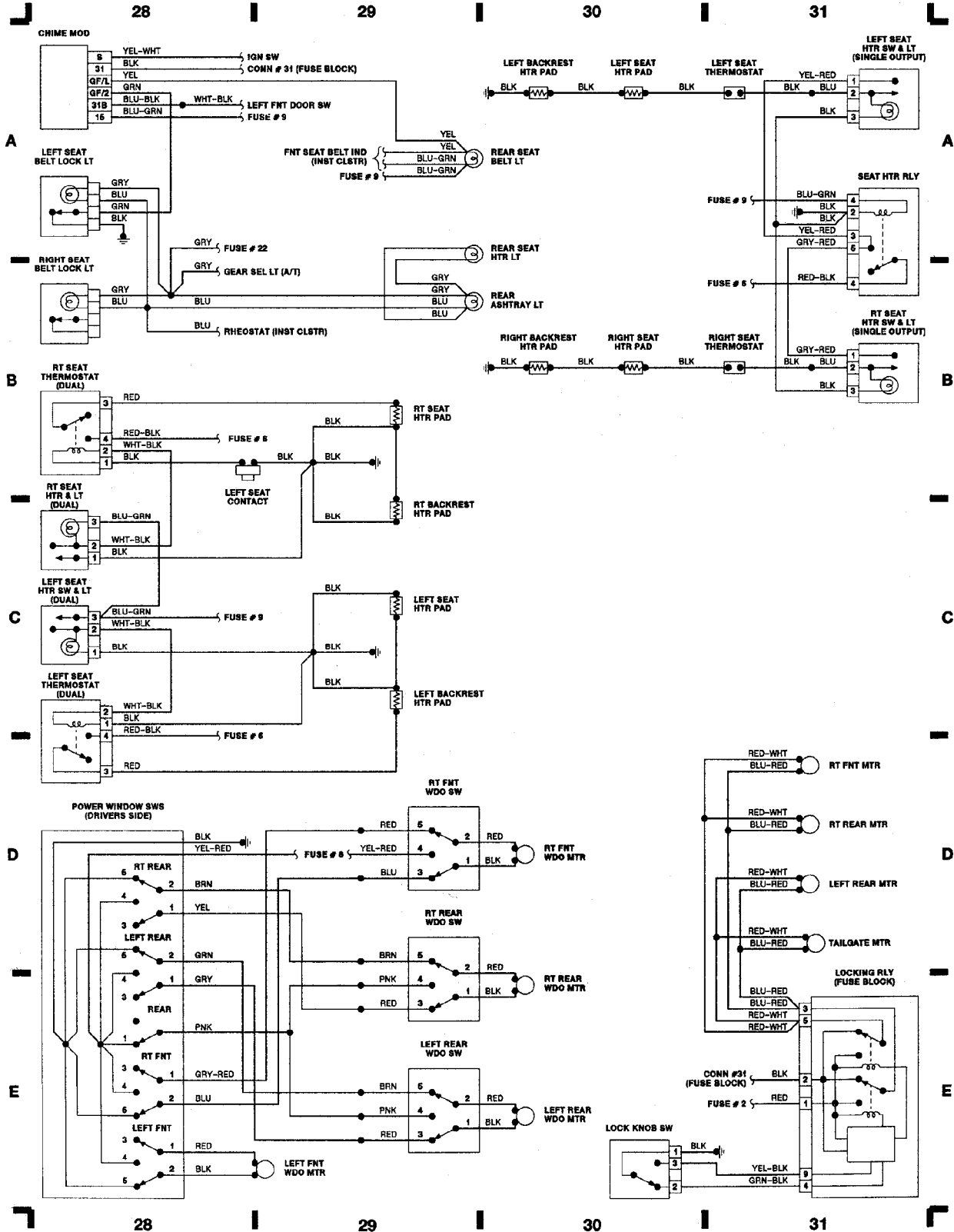

WIRING DIAGRAMS

Fig. 9: Passenger Compartment & Taillights

1988 Volvo 740
For x
Copyright © 1998 Mitchell Repair Information Company, LLC
Friday, July 23, 2004 08:47PM

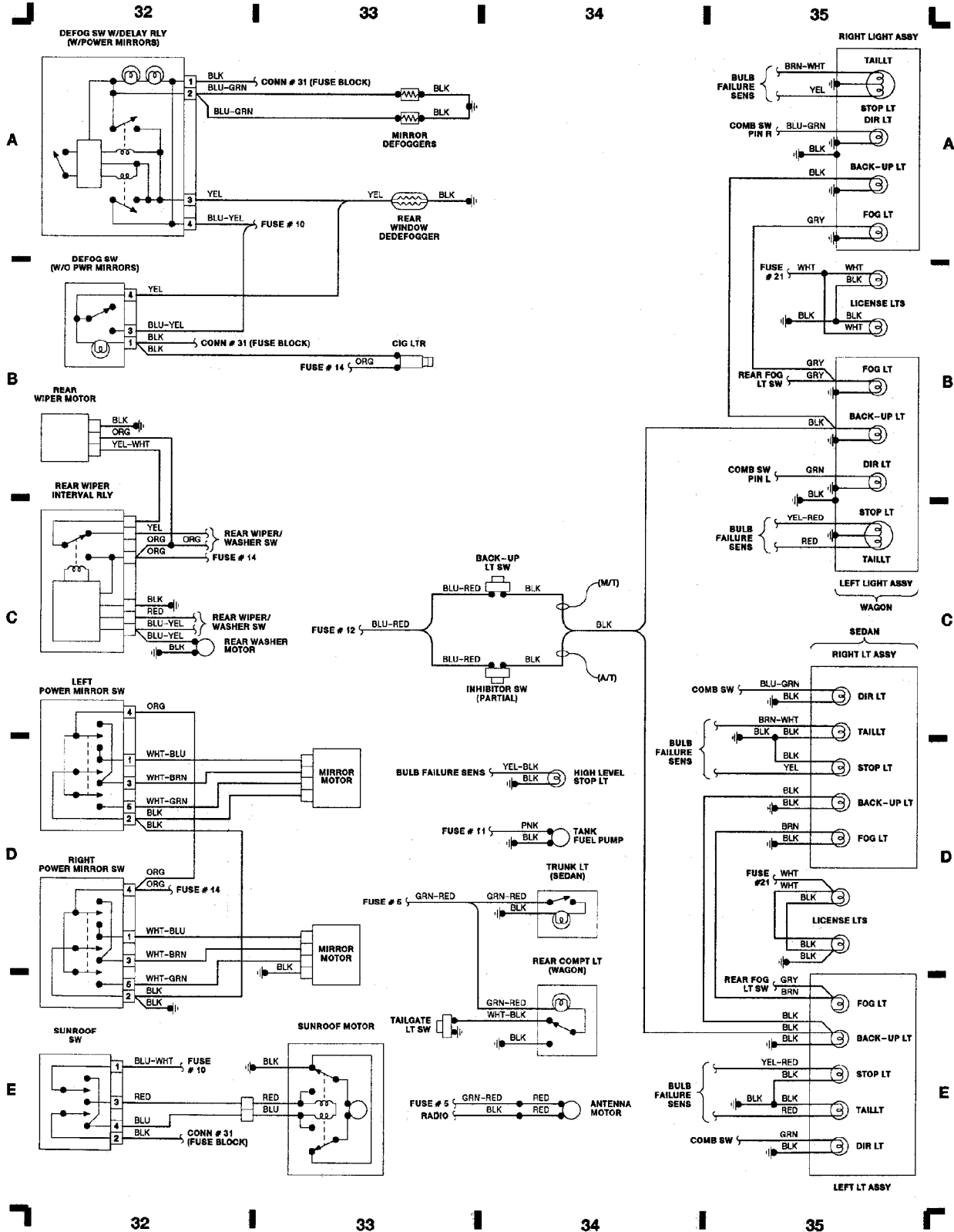

WIRING DIAGRAMS

Fig. 1: Engine Compartment & Headlights

1988 Volvo 740

For x

Copyright © 1998 Mitchell Repair Information Company, LLC

Friday, July 23, 2004 08:46PM

COMPONENT LOCATOR:

A/C & HEATER SYSTEM	B-E 12-15
ALTERNATOR	C 3
ANTENNA MOTOR	E 34
ANTI-LOCK BRAKE SYSTEM (ABS)	A-B 20-23
BACK-UP LIGHT SWITCH	C 33-34
BATTERY	A 2
BRAKE FAIL SWITCH	C 27
BRAKE FLUID LEVEL SENS	C 27
BULB FAILURE SENS	E 16
CHIME MOD	A 18
CHOKE SWITCH	C 27
CIG LIGHTER	B 33
CLUTCH SWITCH	C-D 22
COMB SWITCH	A-B 16
COOLANT TEMP SENS	C 24
COOLING FAN MOTOR/THERMAL SWITCH	B 15
COURTESY LIGHTS	C 16
CRUISE CONTROL SYSTEM	C-D 20-22
DEFOG SWITCH (W/PWR MIRRORS)	A 32
DEFOG SWITCH (W/O PWR MIRROR)	B 32
DELAY RELAY (STD A/C)	D 15
DISTRIBUTOR	D 4
DOOR LIGHTS & SWITCHES	C-D 17-18
ENG COMPT LIGHT	A 3
FLASHER RELAY	A 19
FOG LIGHT RELAY & SWITCHES	D-E 20
FUEL PUMP (MAIN)	C 7
FUEL PUMP (TANK)	D 34
FUEL PUMP RELAY	B 7
FUEL SENS	C 27
FUSE & RLY BLOCK	A-E B-11, A-B 14-15
GEAR SEL LIGHT (A/T)	A 9
GEAR SHIFT RELAY	C 27
GLOVE BOX LT & SW	E 17
HORN SWITCHES	C 2
IGNITION COIL	E 8
IGNITION SWITCH	E 8
IGNITION SYSTEM CTRL UNIT	D-E 4
INHIBITOR SWITCH (A/T)	B 2, C 33-34
INJECTORS	A 4
INSTRUMENT CLUSTER	A-E 24-25
INSTRUMENT PANEL LTS	B 27
INTERVAL RELAY	D 19
JUNCTION BLOCK	A-B 9
LEFT SEAT HEATER LT & SW	C 28
LEFT SEAT THERMOSTAT (DUAL)	C 28
LH JETRONIC CTRL MOD	A-B 4
LIGHT RELAY	B 19
LIGHT SWITCH	A-B 19
LOCKING RELAY	E 31
OIL PRES SENS	C 27
OVERDRIVE RELAY (A/T)	B 12
OVERDRIVE RELAY (M/T)	A 12
POWER MIRROR SYSTEM	C-D 32-33
POWER STAGE FAN RELAY	B-C 12
POWER WINDOW SW	D-E 28
RADIO INTERFERENCE SUPPRESSION RELAY	D 7
READING LIGHTS	D 16
REAR COMPARTMENT LIGHT (WAGON)	D-E 33-34
REAR SEAT BELT LIGHT	A 29-30
REAR WIPER/WASHER SWITCH	D-E 19
REAR WIPER INTERVAL RELAY	C 32
RIGHT FRONT W/O SW	D 29
RIGHT SEAT THERMOSTAT (DUAL)	C 28
SEAT BELT LOCK LIGHTS	A-B 28
SEAT HEATER RELAY	A 31
SPEED SENS	D 27
SRS SYSTEM	C 23
STARTER	B-C 3
STOP LT SWITCH	D 20
SUNROOF SYSTEM	E 32-33
TEMP SENS	A 7
TEST CONN (IGN SYS CTRL UNIT)	D 4
TEST CONN (LH JETRONIC CTRL MOD)	A-B 7
TRUNK LIGHT (SEDAN)	D 34
VACUUM PUMP & RELAY	E 14
VANITY MIRROR LTS & SW	E 18
WIPER/WASHER MOTOR	D 3
WIPER/WASHER SW	C 19

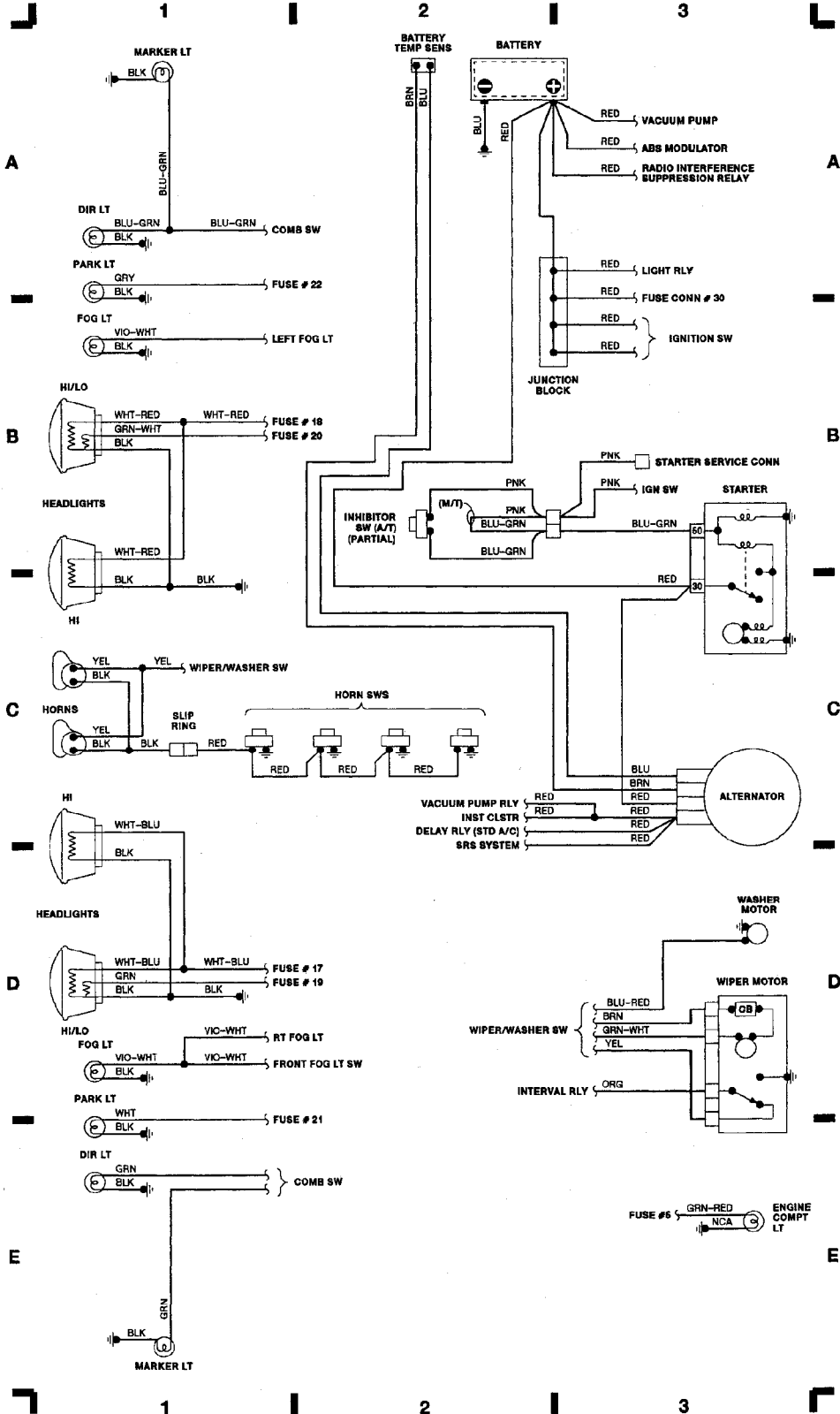

WIRING DIAGRAMS

Fig. 2: Computer Engine Control

1988 Volvo 740

For x

Copyright © 1998 Mitchell Repair Information Company, LLC

Friday, July 23, 2004 08:46PM

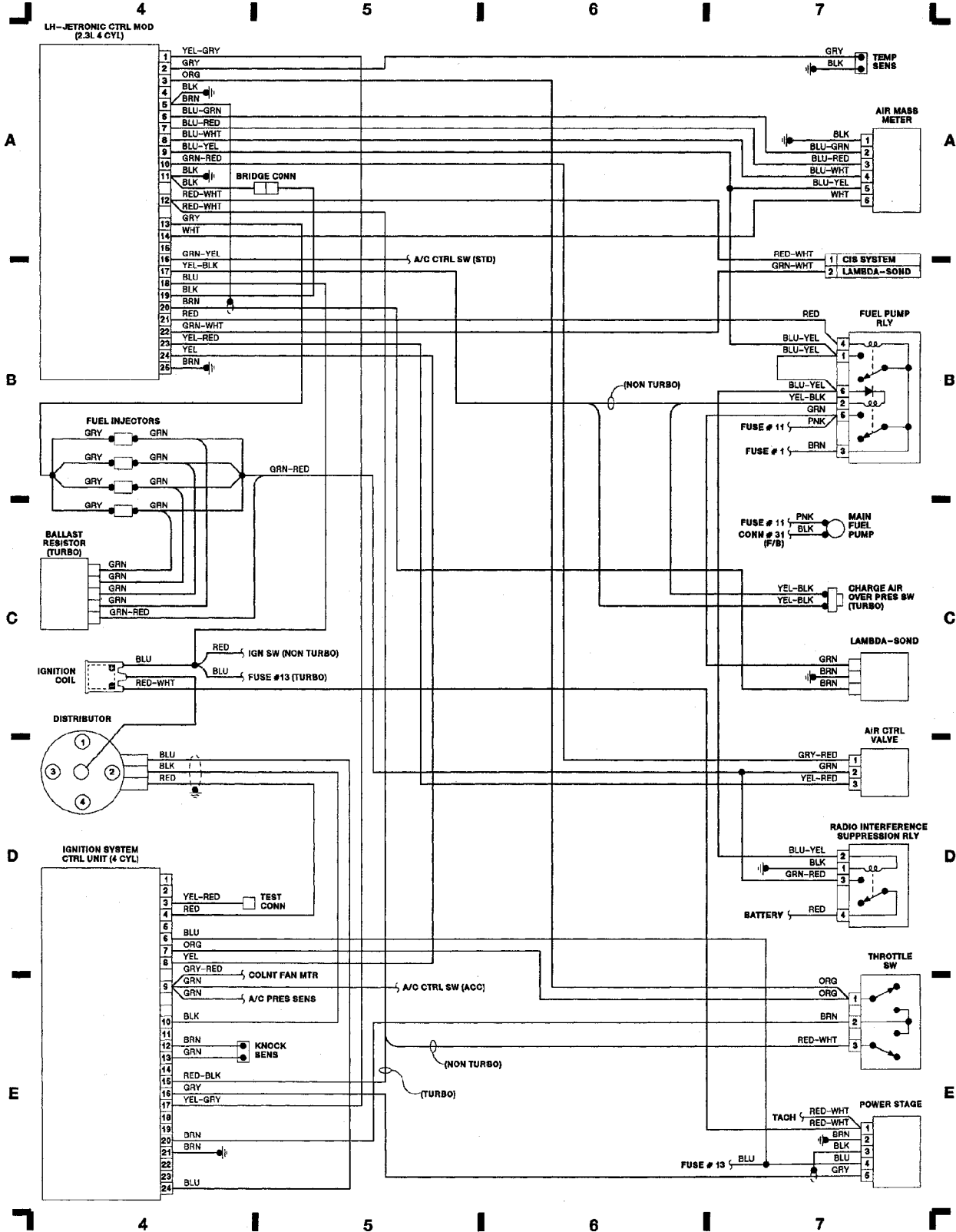

WIRING DIAGRAMS

Fig. 3: Fuse Block

1988 Volvo 740

For x

Copyright © 1998 Mitchell Repair Information Company, LLC

Friday, July 23, 2004 08:46PM

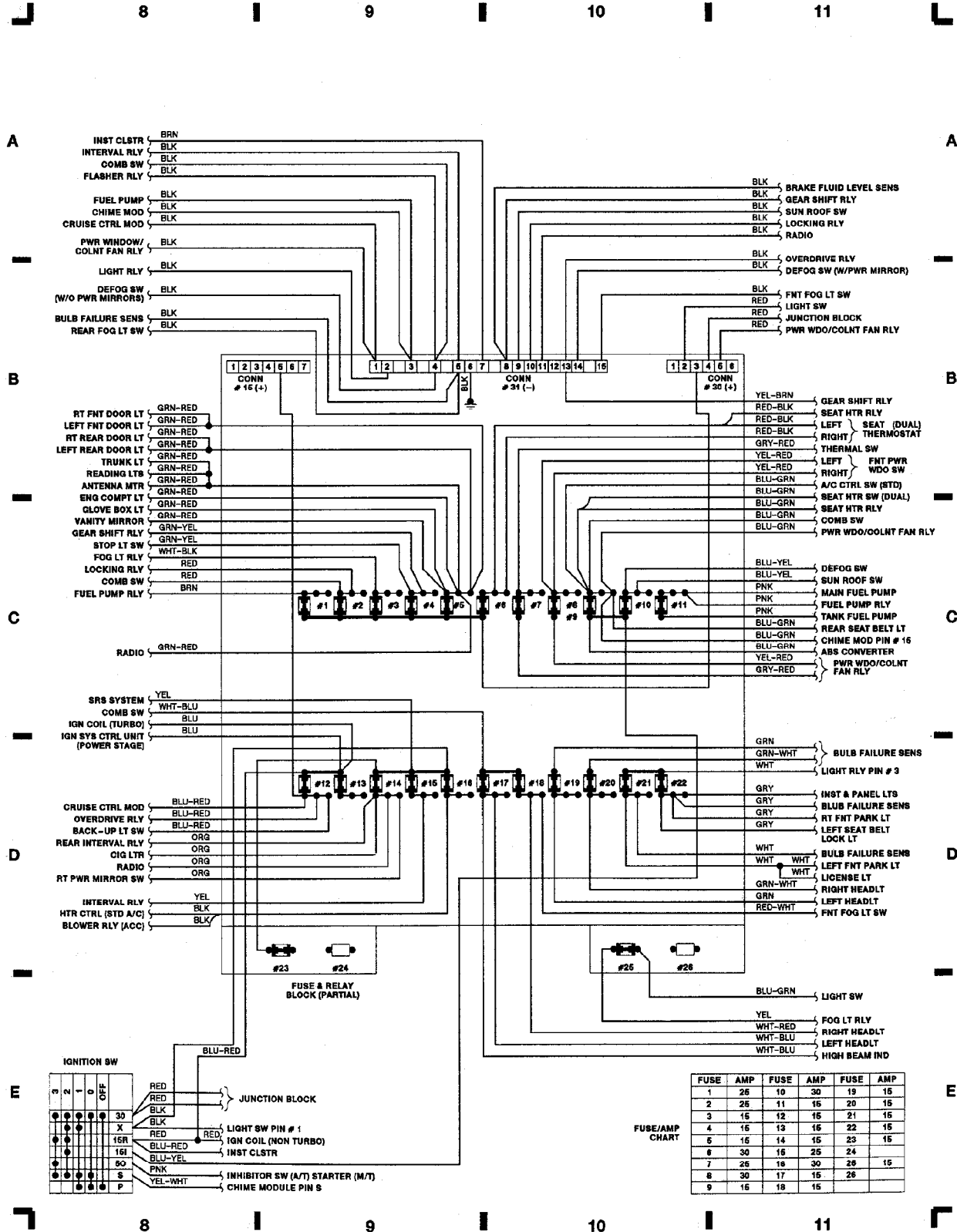

WIRING DIAGRAMS

Fig. 4: Relays, Underdash & A/C & Heating

1988 Volvo 740

For x
Copyright © 1998 Mitchell Repair Information Company, LLC
Friday, July 23, 2004 08:46PM

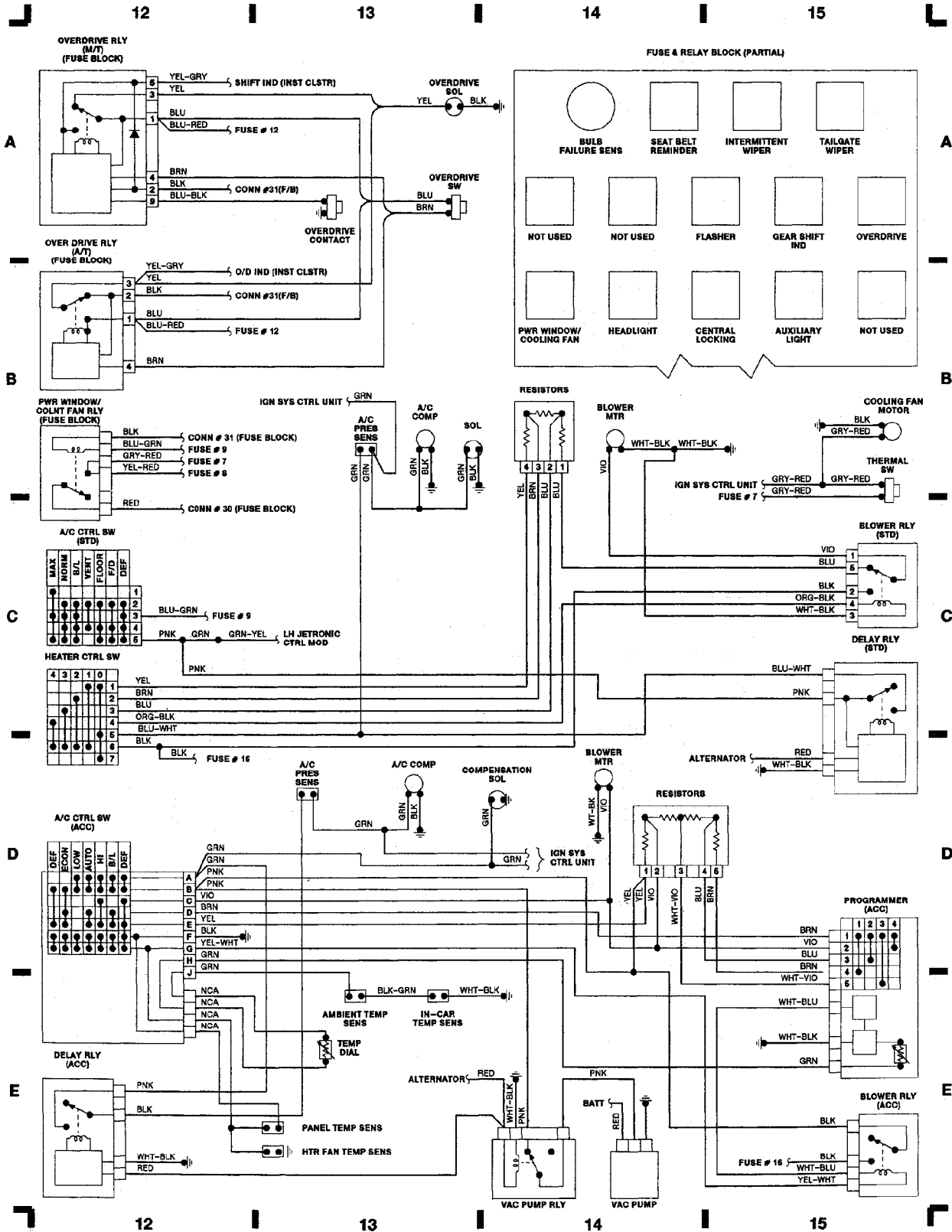

WIRING DIAGRAMS
Fig. 5: Steering Column Switches & Accessories
 1988 Volvo 740
 For x
 Copyright © 1998 Mitchell Repair Information Company, LLC
 Friday, July 23, 2004 08:46PM

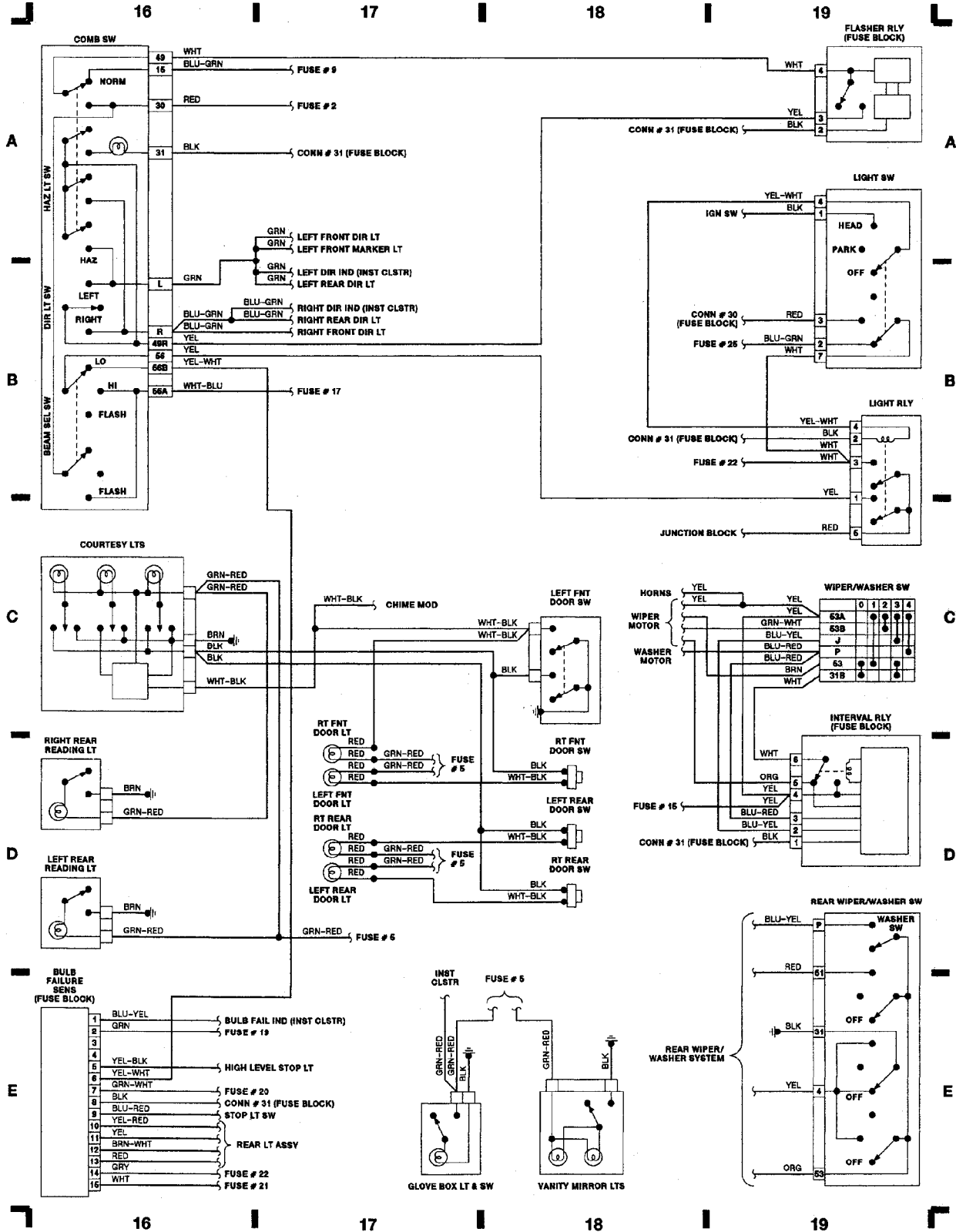

WIRING DIAGRAMS

Fig. 6: Anti-Lock Brake System, Cruise Control & Rear Defogger

1988 Volvo 740

For x

Copyright © 1998 Mitchell Repair Information Company, LLC

Friday, July 23, 2004 08:46PM

