



VOLVO

RE:	PRODUCT
TRAILER HITCH DEVICE	P
	GROUP
	95
DATE	NO.
May 1964	1

Sheet 1 of 2

Instructions for fitting trailer hitch device.

We have designed trailer hitch devices for our passenger car models. These are fitted as described below. All the hitches are designed for a maximum loading of 1000 kg (2200 lb.).

Tightening torques: 5/16" bolts: 1.5-1.8 kgm (11-13 lb.ft.)
1/2" bolts: 7.1-8.6 kgm (50-60 lb.ft.)

PV 544 and PV 444.

Hitch, part number 277480
.....

The position of the hitch in relation to the centre line of the vehicle is determined by the indentations in the rear floor section. The necessary holes in the body are drilled using the hitch as a template, see Fig. 1.

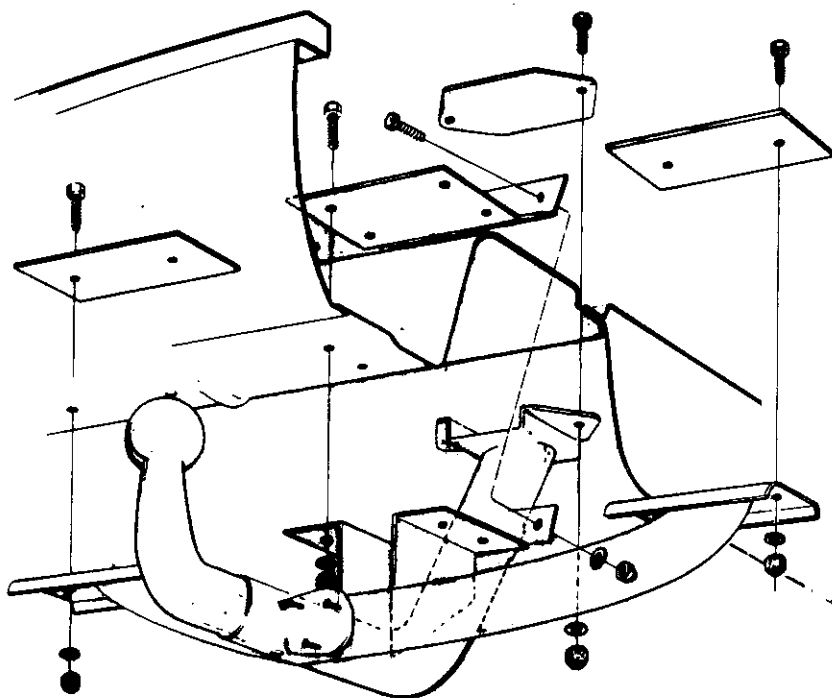

Fig. 1

P 120, 2- and 4-door models

Hitch, part number 277481
.....

The hitch is fitted together with the bumper support bars as shown in Fig. 2. After the hitch has been fitted on the bumper support bars, holes are drilled in the floor of the luggage compartment. This is done using the hitch as a template. The reinforcing pieces are fitted as shown in Fig. 2.

When fitting the hitch, check that the side members above the rear axle and spare wheel well are reinforced as shown in Figs. 3 and 4. Vehicles with effect from the chassis numbers given below are reinforced during manufacture. Vehicles with lower chassis numbers must be reinforced. The necessary material can be ordered from our Accessories Department.

Side members Reinforcement, part number 277327 (set), introduced with effect from chassis numbers: 4-door 112800, 2-door 10500.

Spare wheel well Reinforcement, part number 277484, introduced with effect from about chassis numbers: 4-door 147770, 2-door 54060.

The reinforcement in the spare wheel well is welded on inside the well as shown in Fig. 4. Welding is done along the edges and inside the holes, see the figure.

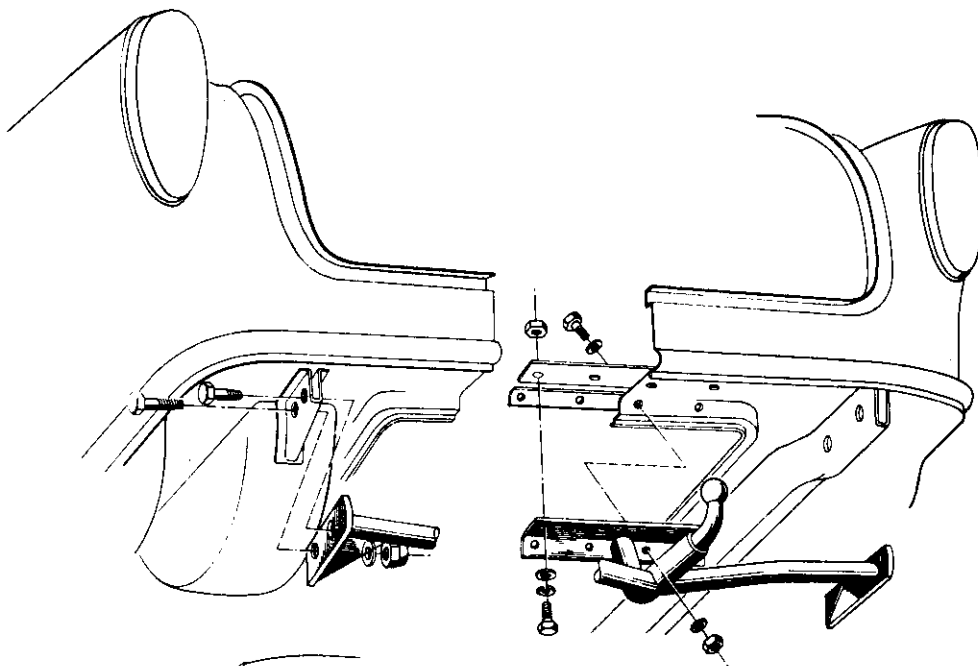

Fig. 2

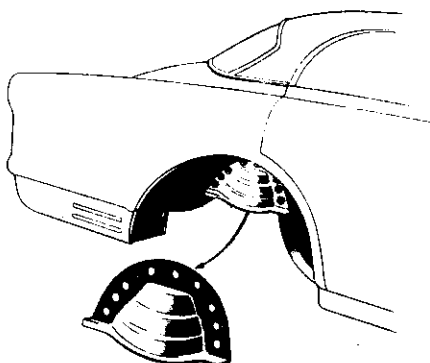

Fig. 3

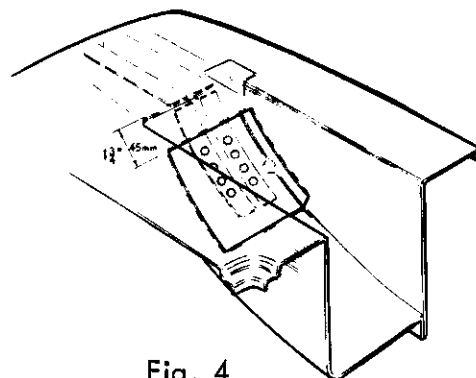

Fig. 4

P 210 and P 445Hitch, part number 277482
.....

The hitch is fitted on the longitudinal and cross-members as shown in Fig. 5.

The bolt holes in the members are drilled using the hitch as a template.

When fitting the hitch on vehicles with B 18 engine, the exhaust tailpipe must be replaced and the bracket for this moved to the cross-member. Exhaust tailpipe part number 669787 is fitted.

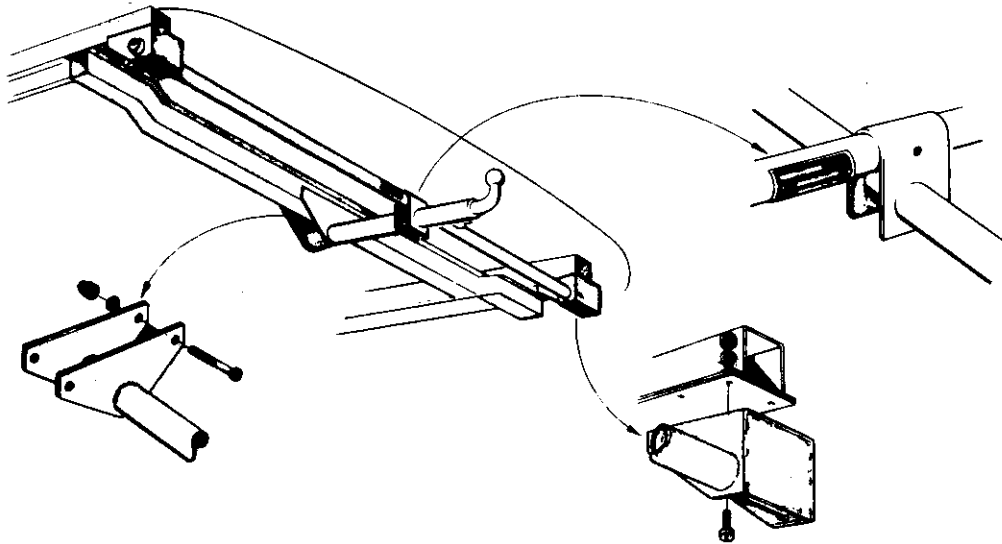

Fig. 5

P 120 Station WagonHitch, part number 277483
.....

The hitch is first fitted in the bumper support bar brackets. The remaining holes in the body are drilled using the hitch as a template, see Fig. 6.

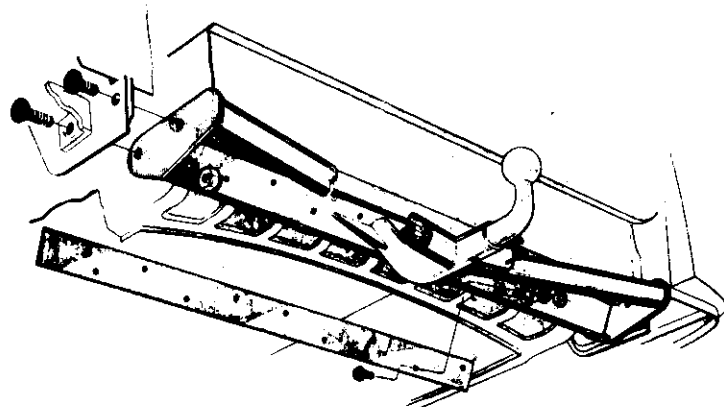

Fig. 6